

## Indexing plungers

for precision locating, plunger conical

### SPECIFICATION

#### Types

- Type **B**: without rest position
- Type **C**: with rest position

#### Steel

- blackened
- Pin hardened and grounded

#### Knob Plastic (Polyamide PA)

- black, matt
- not removable

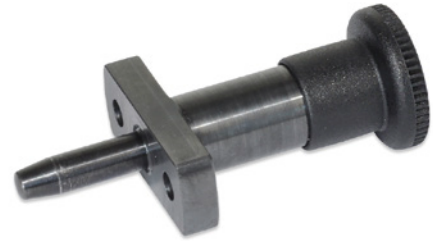

### INFORMATION

Indexing plungers GN 817.5 allow highly accurate positioning, with the guidance made by the positioning bushings DIN 172 / DIN 179 with cylindrical bore. The actual indexing bore is fitted with positioning bushings GN 172.1 / GN 179.1 with conical bores.

The conical shape of the indexing pin / the indexing bore makes the positioning virtually clearance-free and therefore highly precise.

Type C is used for such applications where the plunger has to stay in its retracted position. To achieve this, the knob is rotated by 90° degrees after being retracted. A notch keeps the plunger in this position.

- Range of indexing plungers (see page 738)

### CONSTRUCTION AND ASSEMBLY INSTRUCTIONS

The length  $l_7$  is determined by the penetration depth of the indexing pin into the cone of the bushing.

The length  $l_8$  must ensure that the indexing pin fully disengages, bushing length and plate thickness or us any gap can then be selected within certain margins.

If engaged, the pin must have a minimum remaining stroke of 0.5 mm to make sure that the conical section of the pin is located without clearance in the cone of the guide bushing.

Two different plunger pin lengths  $l_1$  are available for each indexing plunger diameter  $d_1$  (see product table).

For a safe remaining stroke length:  $l_9 = l_1 - 0.5 \text{ mm}$

For mounting bushings with tolerance n6, a hole with tolerance H7 corresponding to the external diameter is usually provided.

A selection of suitable guide bushings DIN 172 (see page 1006) and DIN 179 (see page 1008) with cylindrical bore and guide bushings GN 172.1 (see page 1010) / GN 179.1 (see page 1010) with conical bore.

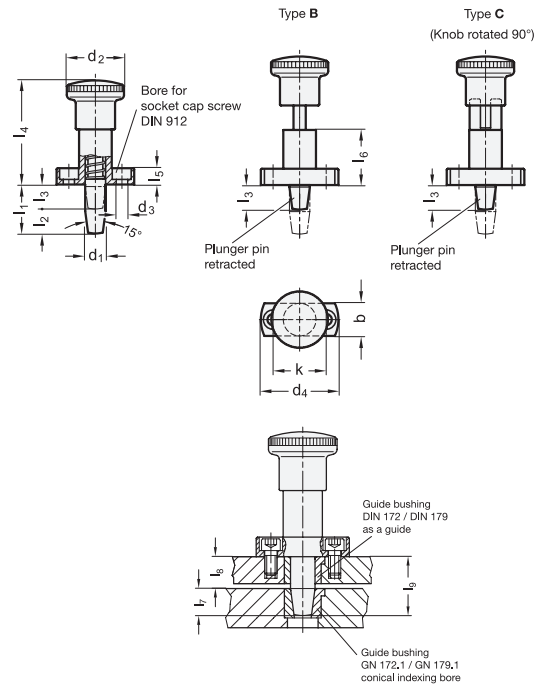

\* Complete with type index of the Indexing plungers (B or C)

<b>B</b>	<b>C</b>
without rest position	with rest position

### GN 817.5

Description	d1 Plunger h6	l1	l2	l3	b	d2	d3	d4	k	l4	l5	l6	l7	l8 min.	l8 max.	l9	Spring load in N ≈ initial	Spring load in N ≈ end	⚖️
GN 817.5-6-18-*	6	18	9	9	13	23	4.3	34	23	45	6	25	7	9	10	17.5	6	25	43
GN 817.5-6-24-*	6	24	9	15	13	23	4.3	34	23	45	6	25	7	15	16	23.5	6	25	50
GN 817.5-8-20-*	8	20	10.6	9.4	16	28	5.3	38	26	51	8	27	9	9.4	10	19.5	8.5	28	75
GN 817.5-8-26-*	8	26	10.6	15.4	16	28	5.3	38	26	51	8	27	9	15.4	16	25.5	8.5	28	80
GN 817.5-10-24-*	10	24	12.6	11.4	16	28	5.3	38	26	51	8	27	11	11.4	12	23.5	11.5	40	83
GN 817.5-10-32-*	10	32	12.6	19.4	16	28	5.3	38	26	51	8	27	11	19.4	20	31.5	11.5	40	87

Weight type B

